



## Document Inserting System DI500/DI600



**Quick Reference Guide**  
US/Canada English Version

## **FCC Compliance**

This equipment has been tested and found to comply with the limits for a Class A digital device, pursuant to part 15 of the FCC rules. These limits are designed to provide reasonable protection against interference when the equipment is operated in a commercial environment. This equipment generates, uses, and can radiate radio frequency energy and, if not installed and used in accordance with the instruction manual, may cause interference to radio communications. Operation of this equipment in a residential area is likely to cause interference, in which case the user will be required to correct the interference at his own expense. Use only a shielded interface cable to operate this equipment with a printer or other peripheral device.

**CAUTION:** Changes or modifications to this equipment not expressly approved by the party responsible for compliance (Pitney Bowes) could void the user's authority to operate the equipment.

## **Canada EMC Compliance**

This Class A digital apparatus complies with Canadian ICES-003.

Cet appareil numérique de la classe A est conforme à la norme NMB-003 du Canada.

SV40226 Rev. A 9/04

©2004 Pitney Bowes Inc. All rights reserved. This guide may not be reproduced in whole or in part in any fashion or stored in a retrieval system of any type or transmitted by any means, electronically or mechanically, without the express, written permission of Pitney Bowes.

We have made every reasonable effort to ensure the accuracy and usefulness of this manual; however, we cannot assume responsibility for errors or omissions or liability for the misuse or misapplication of our products.

Due to our continuing program of product improvement, equipment and material specifications as well as performance features are subject to change without notice. Your inserter system may not have some of the features described in this book.

E-Z Seal and PacPilot are trademarks or registered trademarks of Pitney Bowes Inc. ENERGY STAR is a registered trademark of the United States Environmental Protection Agency.

Printed in the USA or Canada.

## **Important Safety Notes**

Follow these basic safety precautions when operating this machine:

- Use only Pitney Bowes approved supplies, in particular aerosol dusters. Improper storage and use of aerosol dusters or flammable aerosol dusters, can cause an explosive-like condition that could result in a personal injury and/or property damage. Never use aerosol dusters labeled flammable and always read instructions and safety precautions on the duster container.
- To obtain Pitney Bowes supplies, please contact our Supply Line at 1-800-243-7824 or on the web at PB.com. Material Safety Data Sheets can also be acquired from the Supply Line or PB.com.
- Read all instructions before operating the equipment. Only use the equipment for its intended purpose.
- Operation of this equipment without periodic maintenance will inhibit optimum operating performance and could cause the equipment to malfunction. Contact your Pitney Bowes Customer Service Representative for required service schedule.
- Use the power cord supplied with the machine. Plug it and all other supplied power cords into a properly grounded wall outlet that is located near the machine and easily accessible, meaning it is free from obstruction and there is enough room around the unit for servicing.
- The power cord wall plug is the primary means of disconnecting the machine from the AC supply.
- Do not use an adapter plug on the line cord or wall outlet. Do not remove the ground pin from the line cord.
- Avoid using wall outlets controlled by wall switches or shared with other equipment. Do not route the AC power cord over sharp edges, or allow it to be trapped between furniture and/or furniture and the wall.
- Avoid touching moving parts or materials while the machine is in use. Keep hands, loose clothing, jewelry, and long hair away from all moving parts.
- Do not remove covers. Covers enclose hazardous parts that should only be accessed by properly trained service personnel.
- Immediately report to Pitney Bowes Service any damaged or nonfunctioning components. The unit may be unsafe for use.
- To prevent overheating, do not cover the vent openings. Allow ample spacing around the unit for ventilation.

**NOTE:** Always follow the specific occupational safety and health standards for your workplace.

## Machine Identification

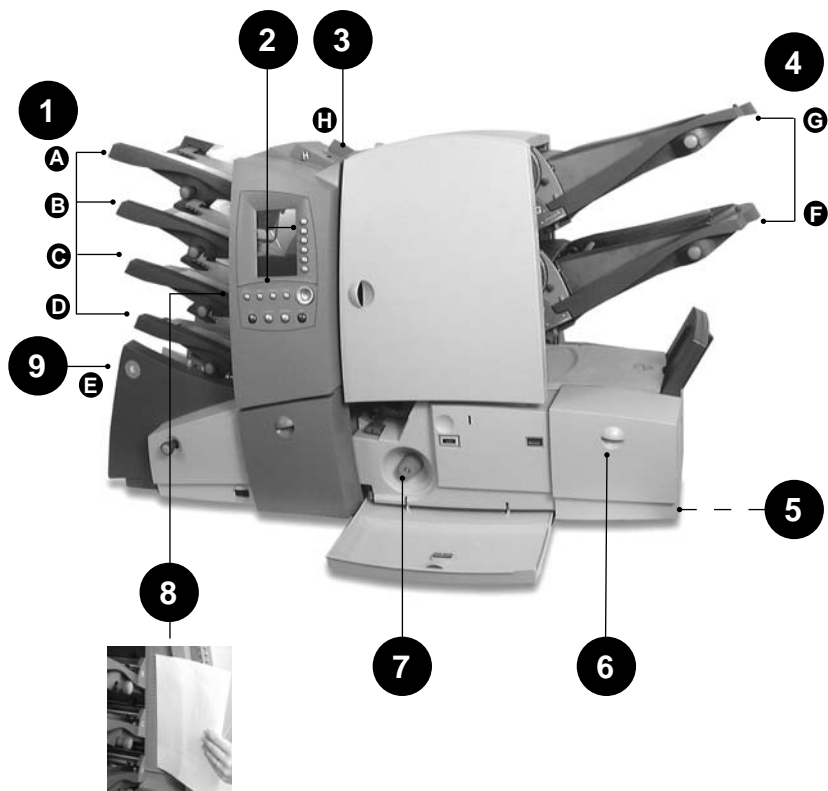

## Machine Identification

- 1 Sheet Feeders** (*A B C D, the number of which depends on model*)  
Feed sheets that require folding. If the double detect feature is turned on, the feeders automatically detect if more than one sheet feeds (double detect), giving security to your mailings.
- 2 PacPilot™ Control Panel**  
Allows you to enter commands to run the machine or configure job settings. The control panel display also shows you the machine status, loading instructions, and details of the job. See the following pages for more information on the controls and screen.
- 3 Manual Feeder** (*H, also known as Convenience or Daily Mail Feeder*)  
Allows you to manually feed stapled or unstapled sets of up to 5 sheets of 20 lb. paper. The machine waits for each set to be manually fed before folding and inserting the set automatically into the envelope. A Supervisor can also configure the machine to place insert(s) within the set if insert feeder(s) are installed.
- 4 Insert Feeder(s)** (*F G, not on all models*)  
Feeds additional inserts to your envelope. Inserts fed from these feeders cannot be folded by the machine, so they must already be folded or be a size that does not require folding.
- 5 Drop Stacker or Power Stacker** (*optional, not illustrated*)  
Located at the exit of the machine to collect and stack neatly the finished mail pieces. The units can be unlatched from the machine when not needed or to allow clearance of stalled material in the inserting/sealing section of the machine.
- 6 Sealer Bottle**  
Located inside an opening cover at the front right side of the machine. It provides sealing solution to the envelope sealer.
- 7 Manual Advance Knob**  
Located inside an opening cover at the lower center of the machine. It can be used to manually turn the machine mechanisms to assist in clearing a material stoppage.
- 8 Measuring Scale**  
Located on the left side of the machine near the sheet feeders and used as an aid in measuring material and envelopes
- 9 Envelope Feeder** (*E*)  
Feeds envelopes into the inserting area where they are filled with the material requested from the other feeder(s).

# DI500/DI600 Quick Reference Guide

---

## PacPilot™ Control Panel

### Function Keys

**Reset Counters** - If only piece count is displayed, press this key to reset the piece count to zero. If both piece and batch counters are displayed, pressing this key allows either or both counters to be reset.

**Help** - Press this key to view an electronic Quick Reference Guide giving you quick access to basic information regarding operation of your machine.

**Cancel** - Press this key to take you back to the previous screen. If you have made changes or defined settings on the screen you are cancelling, these will be lost. Multiple presses of the **Cancel** key will step you back through the screens you have visited until you get back to the Home Screen.

**Home** - Press this key to take you back to the Home Screen. The Home Screen is where you can run jobs and is the start point for accessing the menus.

**Start (green)** - Starts automatic operation.

**Trial Piece (blue)** - Press this key to run test piece(s) so that you can check the machine setup. Trial Piece(s) must be run before automatic operation can be commenced using the **Start** key. If double detection is in use, the machine calibrates itself automatically as it runs the Trial Piece(s). If the job includes an outer envelope, it will be unsealed so that the contents can be easily checked.

**Clear Deck** - Press this key to drive the material through and out of the system. It can be used to clear the machine and make it ready for automatic operation after a stoppage has occurred, etc.

**Stop (red)** - Stops automatic operation at the end of the next cycle.

### Navigation Keys (▲▼◀▶ OK)

These keys are used to move a highlighted area around the display. Once the desired area is highlighted, press the **OK** key to select it. The **▲** and **▼** navigation keys can also be used to change values of machine settings.

### Screen Keys

These are the six round keys located directly to the right of the display. These keys correspond to the changeable options on the display alongside them and therefore are not labelled.

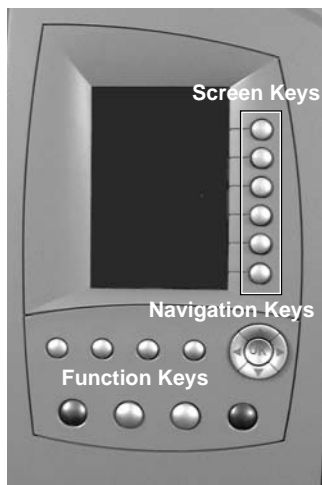

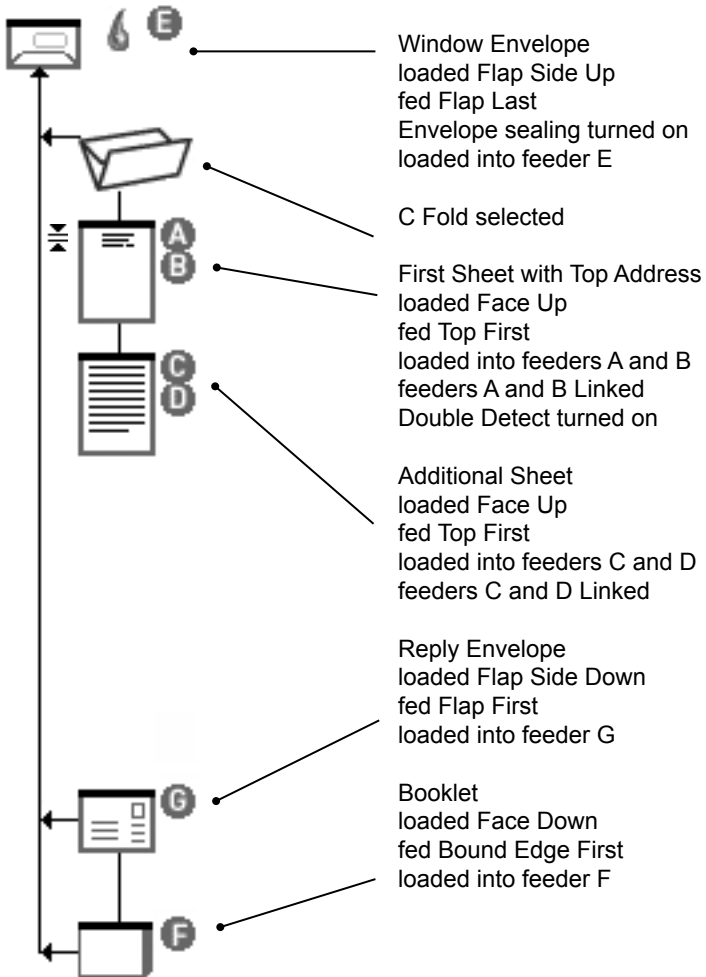

## Mail Piece Icon Tree

When you run, view, or create a job, a Mail Piece Icon Tree displays on the control panel. An example Mail Piece Icon Tree is shown below. This explains the information that is available and how it assists you in loading and running a job. A list of all the icons is provided on the next page.





# DI500/DI600 Quick Reference Guide





## Envelope Icons

|   |  |
|---|--|
|  | No Window,<br>Flap side up,<br>Flap Last |
|  | Window,<br>Flap side up,<br>Flap Last    |





## Seal Icons

|   |              |
|---|--------------|
|  | Seal On      |
|  | Safe Seal On |













## Fold Icons

|   |                            |
|---|----------------------------|
|  | C Fold<br>(letter fold)    |
|  | Z Fold<br>(accordion fold) |
|  | Single Fold                |
|  | Double Fold                |



## Insert Icons

|   |  |
|---|--|
|  | Reply envelope,<br>Flap side down,<br>Flap First |
|  | Booklet,<br>Face Down,<br>Bound Edge First       |
|  | Slip,<br>Face Up,<br>Bottom First                |
|  | Pre-Folded Insert,<br>Closed Side First          |

## Sheet Icons

|   |   |
|---|---|
|    | No address,<br>Face Down,<br>Bottom First     |
|    | No address,<br>Face Down,<br>Top First        |
|    | No address,<br>Face Up,<br>Bottom First       |
|    | No address,<br>Face Up,<br>Top First          |
|    | Top address,<br>Face Down,<br>Bottom First    |
|    | Top address,<br>Face Down,<br>Top First       |
|    | Top address,<br>Face Up,<br>Bottom First      |
|    | Top address,<br>Face Up,<br>Top First         |
|   | Bottom address,<br>Face Down,<br>Bottom First |
|  | Bottom address,<br>Face Down,<br>Top First    |
|  | Bottom address,<br>Face Up,<br>Bottom First   |
|  | Bottom address,<br>Face Up,<br>Top First      |

## Other Icons

|   |                    |
|---|--------------------|
|  | Double Detect On   |
|  | Feeder Designators |

## Running a Job

1. From the PacPilot™ Control Panel, select the job you want to run. If you do not see the job you need, contact your supervisor to define a new job.
2. Using the Mail Piece Icon Tree on the display as your guide:
  - a) Load the sheets into the sheet feeder(s) in the correct orientation. Make sure you fan or aerate the material before loading. Adjust the side guides using the side guide adjustment knob.
  - b) Load the inserts into the insert feeder(s) in the correct orientation. Make sure you fan or aerate the material before loading. Adjust the side guides using the side guide adjustment knob. Set the blue separator gap lever to the **number** required; set the blue separator shield lever to the **letter** required (press **Help** to use the built-in Quick Reference Guide or refer to the Operator Guide on CD for further information on these lever settings).
  - c) Load the envelopes into the envelope feeder. Make sure you fan or aerate the material before loading. Press the envelope feeder loading switch to lower the feeder tray, load the envelopes, then press the loading switch again to raise the feeder back to its normal position.
  - d) If the job requires sealing, make sure the sealer bottle has solution (located under the front right hand side cover of the machine). If necessary, fill the bottle with sealing solution (we recommend Pitney Bowes E-Z Seal™ for best results).
4. Press **Trial Piece** to “test run” one mail piece for your job. This allows the system to calibrate itself to the type of material being run and also allows you to check that the mail piece is being created properly.
5. If everything functions OK, press **Start** for automatic operation. Make sure you keep the feeders full with material while the machine is running.

## If You Run into Problems

- If an error message appears, follow the prompts on the display. If the error cannot be resolved by following the display prompts, contact your supervisor or refer to the Operator Guide on CD.
- If a material stall occurs within the machine, follow the prompts on the display to open the appropriate cover and remove the stalled piece. If necessary, use the manual advance knob to move stalled material through and out of the machine. Press **Clear Deck** to have the machine clear out all other material from the machine. NOTE: The machine has safety interlocks on its covers, whereby the machine will not run when a cover is open. Make sure you close all covers before resuming operation.
- Verify you have selected the correct job
- Verify you have the correct material for your job (inserts, sheets, envelopes).
- Verify your material conforms to the material specifications of the machine (see the Operator Guide on CD).

# ***DI500/DI600 Quick Reference Guide***

---

## **If You Need Assistance**

- For basic operations questions, use the built-in Quick Reference Guide by pressing **Help** on the PacPilot™ Control Panel.
- For more detailed troubleshooting or setup help, consult the Operator Guide on CD.

## ***USA Contacts***

- Product Name - DI500 or DI600
- For frequently asked questions, go to: [www.pb.com](http://www.pb.com) and click on **Customer Support**.
- To place requests for service or training, go to: [www.pb.com](http://www.pb.com) and click on **My Account**.
- To order PB supplies and accessories, go to: [www.pb.com](http://www.pb.com) and click on **Online Store**.
- To view and pay invoices online, go to: [www.pb.com](http://www.pb.com) and click on **My Account**.
- To view inventory, go to: [www.pb.com](http://www.pb.com) and click on **My Account**.
- For direct questions, call: 1.800.522.0020. Customer Service Representatives are available Monday through Friday, 8:00 AM - 8:00 PM ET.

## ***Canada Contacts***

- Product Name - DI500 or DI600
- For frequently asked questions or to order supplies, go to: [www.pitneybowes.ca](http://www.pitneybowes.ca)
- For direct questions, call: 1.800.672.6937. Customer Service Representatives are available Monday through Friday, 8:30 AM - 4:00 PM ET.



*Engineering the flow of communication™*

1 Elmcroft Rd.  
Stamford, Connecticut 06926-0700  
[www.pitneybowes.com](http://www.pitneybowes.com)

5500 Explorer Drive  
Mississauga, Ontario L4W 5C7  
[www.pitneybowes.ca](http://www.pitneybowes.ca)

PB Form SV40226 Rev A (9/04)

Printed in the USA or Canada



Printed on recyclable paper



\* S V 4 0 2 2 6 R E V A \*